

# PowerStacker® Conveyor



## Quick Transition from Road to Work

From one location, the hydraulic control center performs all the functions to convert your PowerStacker conveyor from transport to stockpile mode and back again.

- ▶ Fold to unfold
- ▶ Raise and lower
- ▶ Move conveyor over radial arc

## Patented FD axle Assembly

With one lever and no tools, the PowerStacker conveyor's FD axle assembly shifts from road ready to radial travel position in a minute.

- ▶ Avoid using road travel tires for radial travel function
- ▶ Enclosed power travel protected from exposure to environment
- ▶ Radial travel tires hydraulically engage while road travel tires lift

## Patented Power Folds

This long-lasting system is designed to provide extra protection to the hydraulic cylinders while the conveyor is operating in its stockpile position.

- ▶ Cylinder rod protected from elements during operation
- ▶ Lever actuated folding and unfolding
- ▶ Double acting cylinders

## Warranty and Support

Superior stands behind their work! Backed by the strongest warranty program in the industry, our products are guaranteed tough.

- ▶ 5 year complete structural warranty
- ▶ 2 year complete conveyor warranty
- ▶ 2 year complete components warranty
- ▶ Local dealer support network



Patented FD axle assembly quickly transforms from road to work.



Patented power fold protects hydraulic cylinders from contaminants.

# PowerStacker Conveyor

## Operating Specs

Conveyor Length	A	95'	110'	125'	150'
Conveyor Ground Length	B	88' 4"	102'	116' 1"	140' 4"
Raised Height to Center of Pulley	C	32' 3"	36' 4"	41' 4"	48'
Lowered Height to Center of Pulley	D	13' 8"	17' 2"	17' 7"	15' 2"
Anchor Pivot to Center of Axle	E	47' 7"	56' 3"	59' 11"	79' 2"

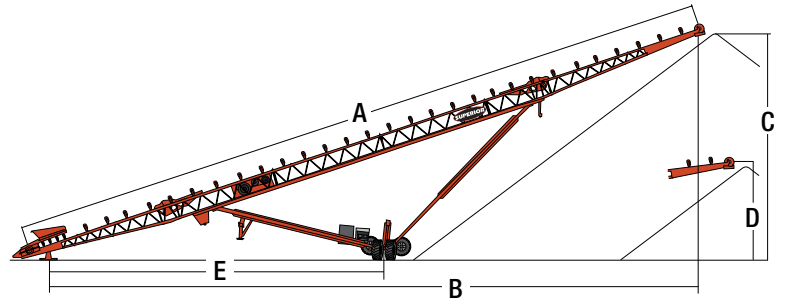

## Transport Specs

Conveyor Length		95'	110'	125'	150'
Travel Length	A	78' 7"	60' 9"	70' 9"	80' 6"
Travel Height	B	13' 6"	14' 1"	14'	13' 10"
Tail to Kingpin	C	5' 1"	6'	6'	5' 9"
Kingpin to Axle	D	50' 11"	29' 2"	33' 6"	49' 6"
Axle to Head	E	22' 8"	25' 8"	31' 3"	25' 3"
FD Axle Size		FD15	FD20	FD40	FD50
Weight at Axle		17,750	19,940	33,000	34,200
Weight at Kingpin		4,000	3,060	3,500	10,200

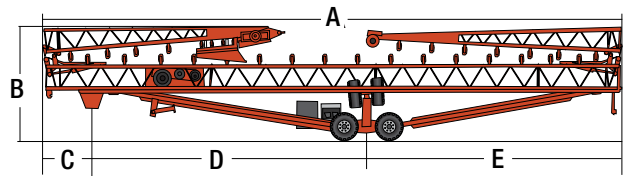

## Stockpile Dimensions

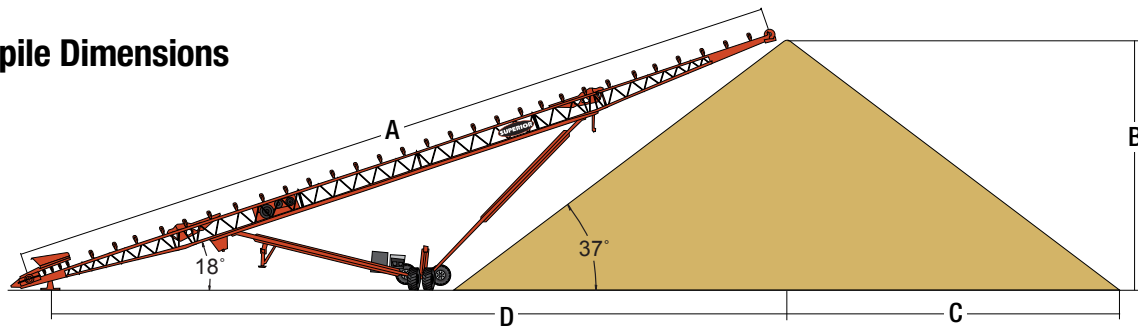

Conveyor Length	A	95'	110'	125'	150'
Stockpile Height	B	31'	35' 6"	39' 5"	47' 6"
Radius of Pile	C	41' 1"	47' 1"	52' 5"	63'
Anchor Pivot to Center of Pile	D	91'	105' 6"	119'	144'

## Stockpile Volumes (Tons)

PowerStacker Conveyor	36" x 95'	30" x 110'	36" x 125'	36" x 150'
Conical Pile Volume	2,747	4,125	5,355	9,271
90° Stockpile Volume	11,857	17,845	27,100	41,700

Conical Stockpile
  90° Stockpile Volume

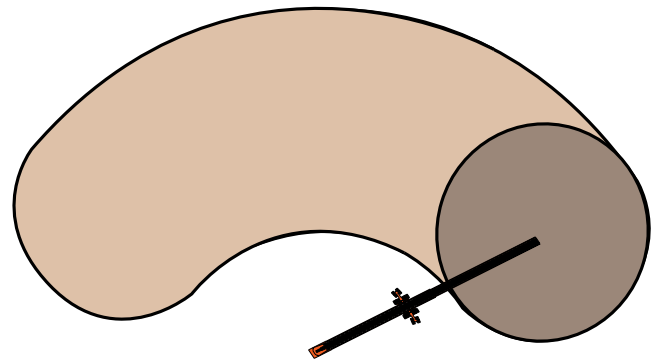

For more information or to locate a dealer near you:  
[www.superior-ind.com](http://www.superior-ind.com) or call 1-800-321-1558

